

GREYSTONE ENERGY SYSTEMS INC

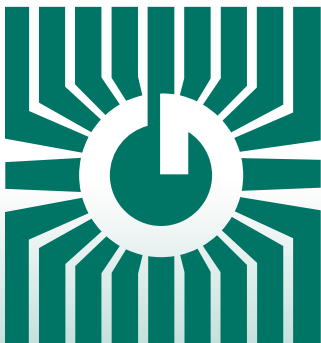

LOW LIMIT TEMPERATURE THERMOSTAT TTL Series



Precision Temperature sensing/control

FEATURES:

- Precision Thermistor
- Various Configurations Available
- Selection of Enclosures
- Relay Output with Adjustable Setpoint
- Custom Laser Etching Available

*Peace of mind
through reliable
temperature monitoring*

GREYSTONE HAS AN ISO 9001 REGISTERED QUALITY SYSTEM

SPECIFICATIONS:

Power Supply.....	12 to 28 Vac/dc
Consumption.....	50 mA max
Relay Contacts.....	SPDT, Form C contacts (N.O. and N.C.) 5 Amps @ 30 Vdc / 250 Vac resistive 1.5 Amps @ 30 Vdc / 250 Vac inductive
Relay Action.....	Activates on temperature fall
Setpoint Operation.....	Single-turn knob-pot on pcb
Adjustable Setpoint.....	-4 to 10°C (25 to 50°F)
Setpoint Temperature	Low/Mid/High jumper selectable
Differential	1.1/2.8/5.6°C (2/5/10 °F)
Temperature Sensor.....	10K ohm curve matched precision thermistor
Sensor Accuracy.....	±0.2°C, 0 to 70°C (±0.36°F, 32 to 158°F)
Probe Sensing Range.....	BM, CN/CS, DR, GL, RP, SO: -20 to 105°C (-4 to 221°F) DC, DF, FL, RN/RS: -20 to 60 °C (-4 to 140 °F)
Probe Material	BM, CN/CS, DR, FL, RN/RS, RP: 304 Series Stainless Steel DC: Soft copper GL: Aluminum SO: Aluminum plate w/ compressible foam backing
Probe Dimensions.....	CN/CS, DR, BM, FL, RN/RS, RP: 6.35 mm (0.25") Diameter DC: 7.94 mm (0.3125") Diameter GL: 31.75mm L x 95.25mm W x 9.525mm H (1.25" x 0.375" x 0.375") SO: 38 mm (1.5") square
Wire Material.....	BM, CN/CS, GL, OS, RP, SO: PVC insulated, parallel bonded FL, DC, DF, RN/RS: FT-6 Plenum-rated DR: Kynar, PVDF, 28 AWG
Operating Conditions.....	-10 to 50°C (14 to 122°F), 5 to 95% RH non-condensing
Storage Conditions.....	-30 to 70°C (-22 to 158°F), 5 to 95% RH, non-condensing
Enclosure	(A) ABS, UL94-5VB, IP61 (NEMA 2) (D)-ABS, UL94-5VB, IP65 (NEMA 4X)
Wiring Connections.....	Screw terminal block (14 to 22 AWG)

WIRING:

Terminal	Function
PWR	Power Supply
COM	Power Supply Common
TEMP (2)	Temperature Sensor Input
NO	Relay Output - Normally Open Contact
COM	Relay Common
NC	Relay Output - Normally Closed Contact

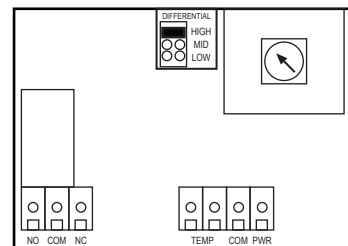

PRODUCT ORDERING INFORMATION:

MODEL	Product Description
TTL	Low Limit Temperature Thermostat

CODE	Mounting Style
BM	Duct
DC	Duct average, copper probe
DF	Duct average, flexible cable
DR	Duct average, rigid stainless steel probe
CN	Immersion, Nylon Fitting, 1/2" NPT
CS	Immersion, Brass, Spring-loaded Fitting, 1/2" NPT
RN	Immersion w/Remote Probe, Nylon Fitting, 1/2" NPT
RS	Immersion w/Remote Probe, Spring-loaded Fitting, 1/2" NPT
RP	Strap-on - Remote Probe
SO	Strap-on - Assembly clamps around pipe with aluminum plate c/w 254 mm (10") stainless clamp
OS	O.S.A.
FL	Flying lead
GL	Glass

CODE	Enclosure
A24	ABS enclosure
D24	ABS Enclosure, Hinged Cover

CODE	Probe Length	Lengths are applicable to these Mounting Styles
A	50 mm (2")	BM, RP, RN, RS, CN & CS
B	100 mm (4")	BM, RP, RN, RS, CN & CS
C	150 mm (6")	BM, RP, RN, RS, CN & CS
D	200 mm (8")	BM, RP, RN, RS, CN & CS
E	300 mm (12")	BM
F	450 mm (18")	BM, DR
G	600 mm (24")	DR
H	900 mm (36")	DR
I	1800 mm (6')	DC, DF
J	3600 mm (12')	DC, DF
K	6100 mm (20')	DC, DF
L	7300 mm (24")	DC, DF

OMIT FOR SO, OS, FL & GL

CODE	Adjustable Setpoint Range
1	-4°-10°C (25°-50°F)

ENCLOSURE DIMENSIONS:

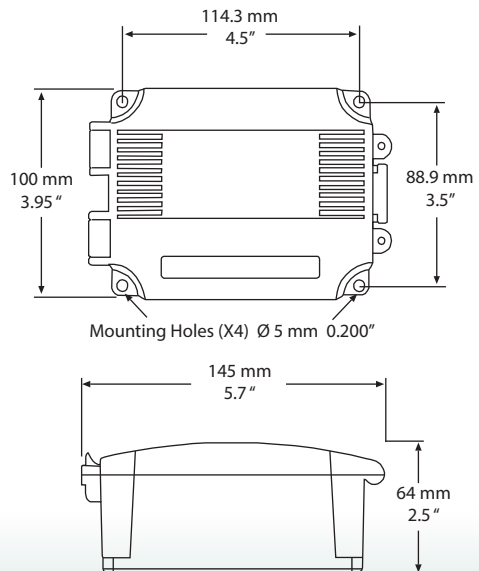
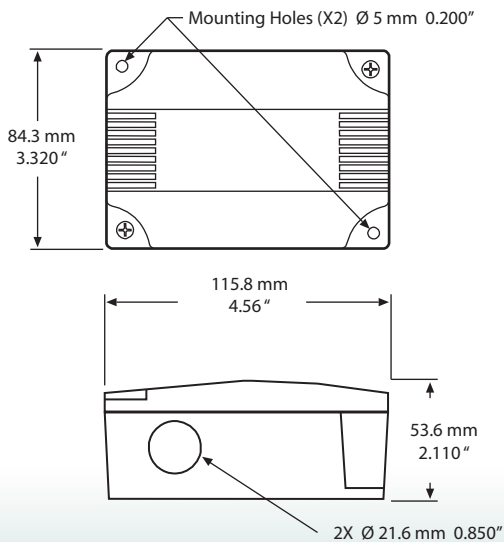

TTL - PROBE TEMPERATURE THERMOSTAT CONFIGURATIONS

FEATURES:

The TTL Series Low Limit Temperature Thermostat combines a precision thermistor and a relay output with adjustable setpoint in wide variety of mounting configurations. The TTL series can be interfaced with a computerized monitoring or control system.

BM) Duct Sensor – The BM is for single point monitoring. It comes with a stainless steel probe which is available with various probe lengths and enclosures.



CN/CS & RN/RS) Immersion Sensor – The CN/CS & RN/RS come in two configurations either spring loaded or non-spring loaded probes and have a 1/2" NPT fitting to be mounted into a thermowell. The RN/RS is provided with 1.524 (5') of cable for remote mounting of the probe. It is available in various lengths and enclosures.



DF, DC & DR) Duct Averaging Sensor – The DF, DC & DR models incorporate numerous sensors along the assembly and act as a single sensor averaging the temperature across the sensors. They are available in various lengths. The DF probe is constructed of FT-6 rated plenum cable which allows for easy installation. The DC probes are constructed of bendable soft copper and the DR is a constructed of rigid stainless steel. Various enclosures are available.



RP & SO) Strap-on Sensor – The RP comes with stainless steel probe and is available in several lengths and 1.5 m (5') of zip cable for remote mounting. The SO has an aluminum plate with an expandable 10" clamp assembly to strap directly to a pipe. Various enclosures are available.



OS) OSA Sensor – The OS comes in a hinged weatherproof ABS enclosure and incorporates a sun/wind shield to protect the sensor.



FL) Flying Lead – The FL comes with a 2" stainless steel probe and 1.8 m (6') of FT6 plenum rated cable for remote mounting. Various enclosures are available.



GL) Glass – The sensor is encapsulated in a 1/2" square x 2" aluminum wafer that can be affixed to any surface. It comes with 5' of zip cable and various enclosures are available.



RoHS
COMPLIANT



Greystone Energy Systems Inc. is one of North America's largest ISO registered manufacturers of HVAC/R sensors and transmitters for Building Automation Management Systems.

We have conscientiously established a worldwide reputation as an industry leader by maintaining leading-edge design technology, prompt technical support, and a commitment to on-time deliveries. We take pride in our Quality Management System which is ISO 9001 certified, assuring our customers of consistent product reliability.

GREYSTONE HAS AN **ISO 9001** REGISTERED QUALITY SYSTEM